



BRAKCO | 2022

Eco-conscious

Copper free formulation

Copper free ceramic and Kevlar disc pads sacrifice no performance and quality but are better for our environment.

Furthermore, the new formula has dramatically reduced the heat and noise and increases the braking power during braking by using multiple fiber and eco-friendly mineral ingredients after years research and development to meet E-bike brake use.

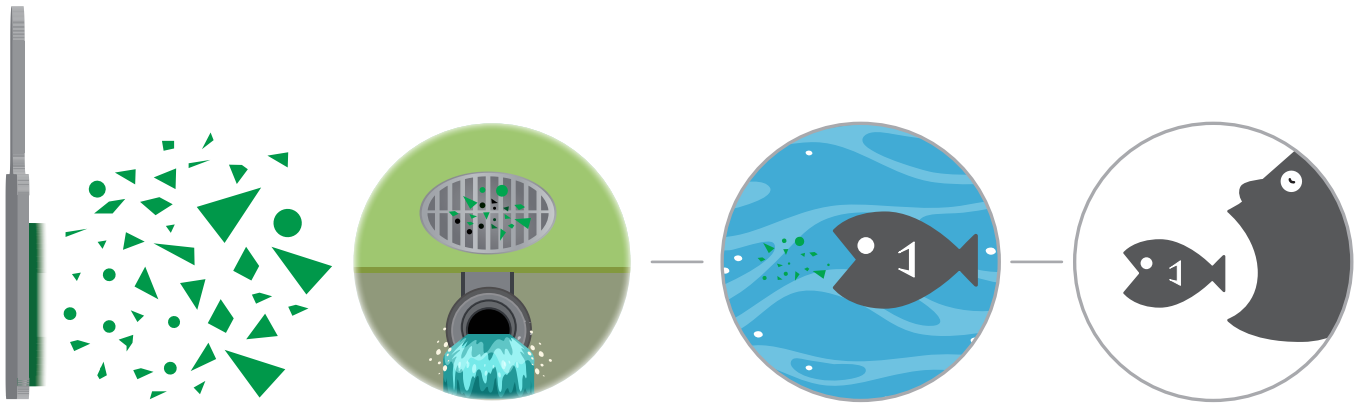

Debris from brake pads containing copper is released and ends up in runoff and waterways. Copper may be toxic to aquatic organisms which are the base of the food chain

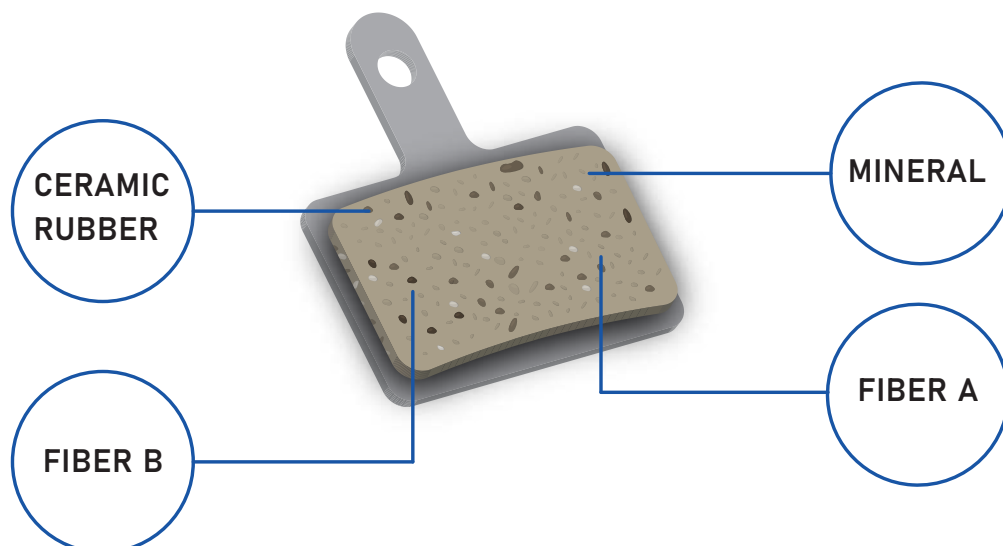

ROTOR

FRC-11SA SXP

Floating rotor designed specifically for racing bikes.

Heat is the enemy of braking performance. The longer and harder you brake, the more heat that builds in the brake system especially on the rotor braking band. As heat builds quickly, the braking band expansion would lead to rotor heat warp and rubbing especially for relatively heavier E-bikes and racing bikes.

By heating up our SXP range rotor to 430+ Celsius degree in seconds by heavily pulling the brake lever under the speed 60km/hour, we still have a true rotor and consistent braking thanks to the floating rivet design to absorb the expanding braking band.

CHARACTERISTICS:

- ✓ Efficient heat-dissipation braking band and spider design
- ✓ Aerospace grade AL7075 fully precision CNC machined spider
- ✓ Japan SUS braking band
- ✓ Precise machined stainless rivet and German reinforced washers

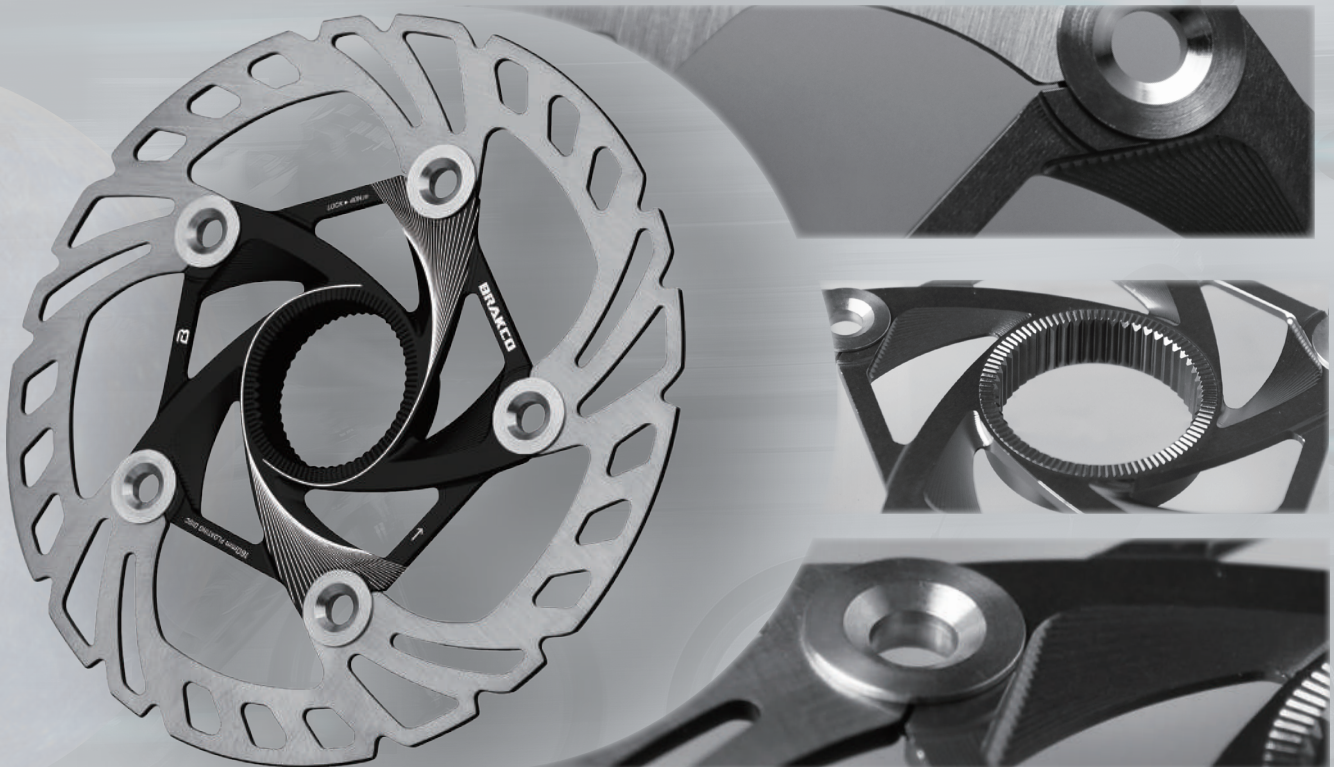
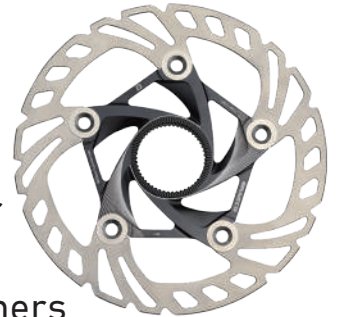

Available in 140/160/180

DR-17-XSC

E-BIKE EXTRA THICK ROTOR

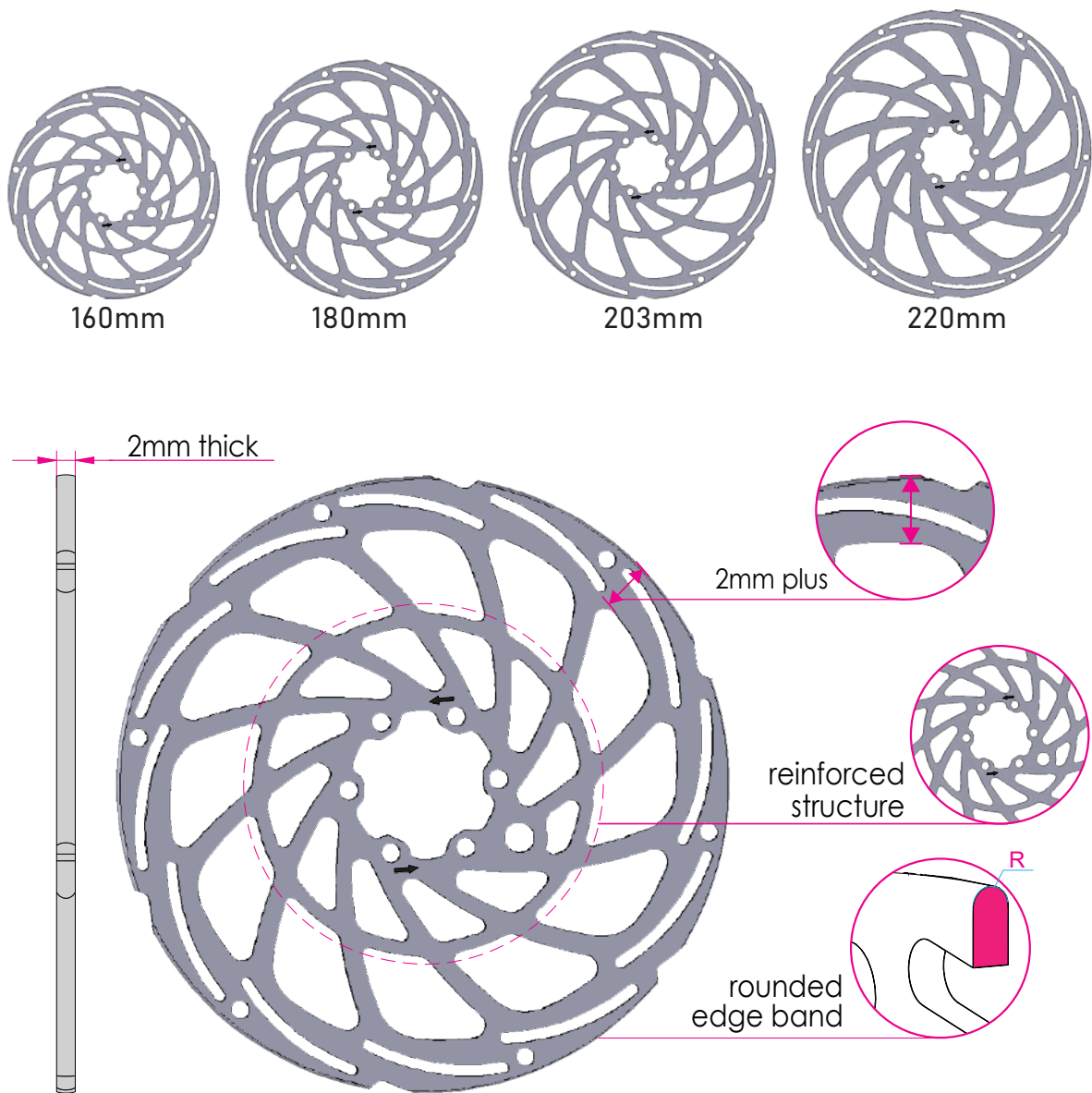

Maximum performance and safety for e-bike
Optimized for use on e-bikes, the advanced rotors provide enhanced performance and stability – and they also reduce vibration by

1. extra 2mm thickness
2. reinforced structure
3. 2mm wider braking band
4. Available in 160/180/203/220



wear-out indicator

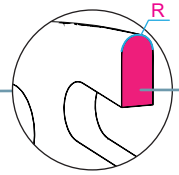
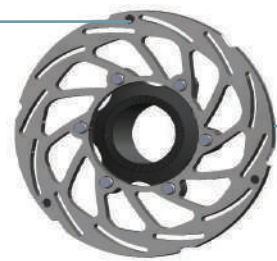
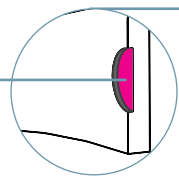

rounded braking band

FRC-01SS / FRC-01SA / FR-01SA / DR-17 / DR-19

DR-19 For Rohloff® rear gear hub

Spec:
M8x0.75x8.5

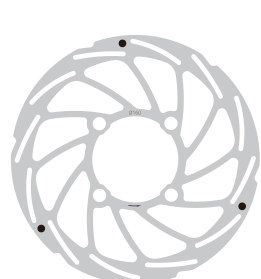

160mm

Thickness 1.8mm : 117g
Thickness 2.0mm : 124g

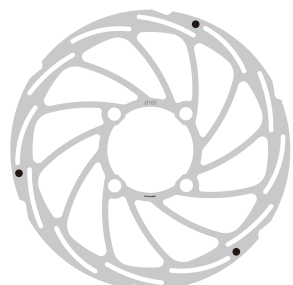

180mm

Thickness 1.8mm : 132g
Thickness 2.0mm : 143g

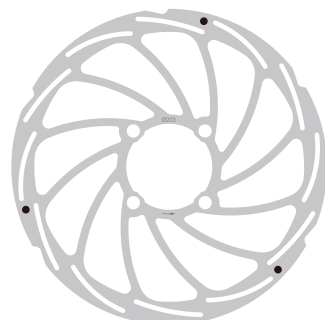

203mm

Thickness 1.8mm : 173g
Thickness 2.0mm : 186g

DR-17

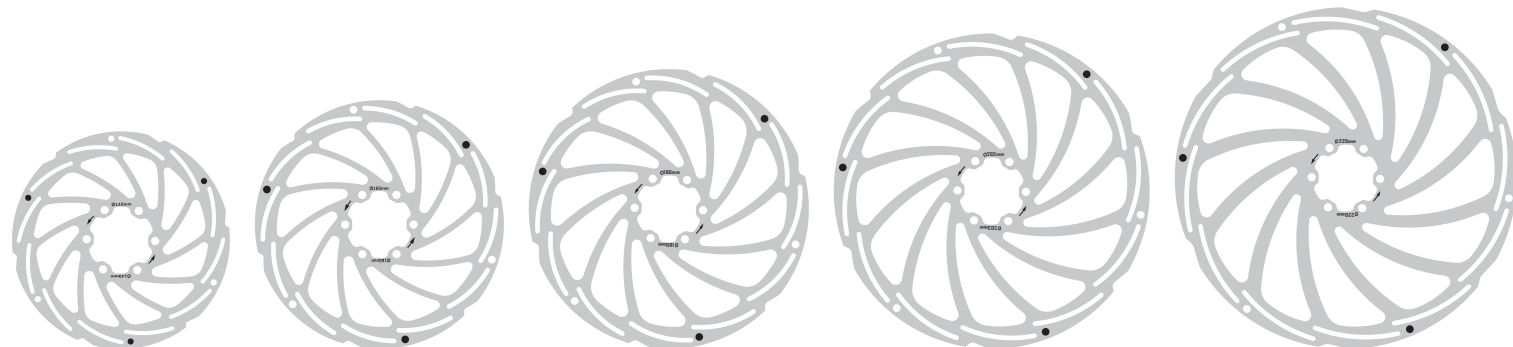

140mm

103g

160mm

121g

180mm

153g

203mm

190g

220mm

249g

2mm extra thickness,
more heat absorbed

FRC-01SS Thickness 1.8mm Available : 140 / 160 / 180 / 203mm
Thickness 2.0mm Available : 160 / 180 / 203mm

CENTERLOCK

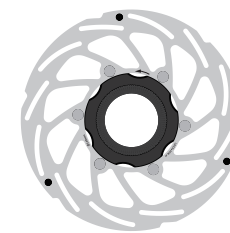

140mm

Thickness 1.8mm : 139g

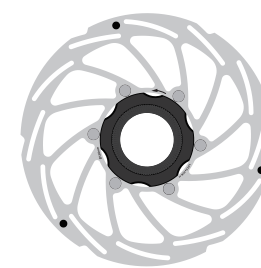

160mm

Thickness 1.8mm : 155g

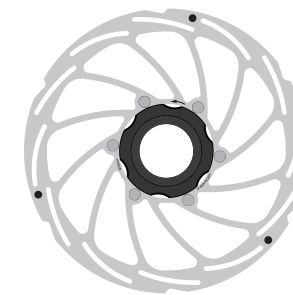

180mm

Thickness 1.8mm : 175g

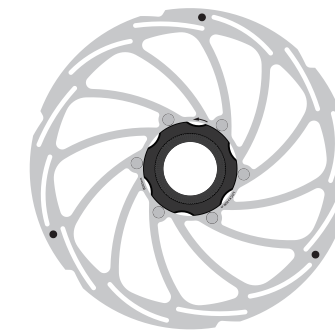

203mm

Thickness 1.8mm : 212g

FRC-01SA

CENTERLOCK

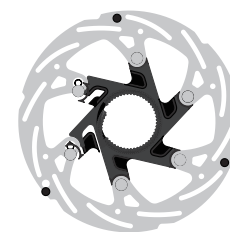

140mm

123g



160mm

149g

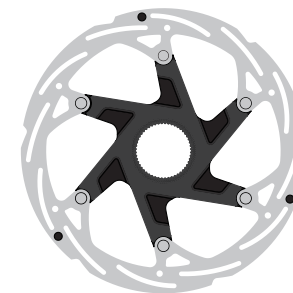

180mm

176g



203mm

214g

FR-01SA

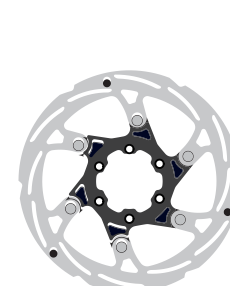

140mm

109g



160mm

133g

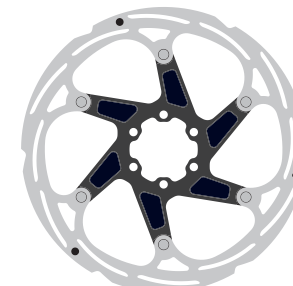

180mm

153g

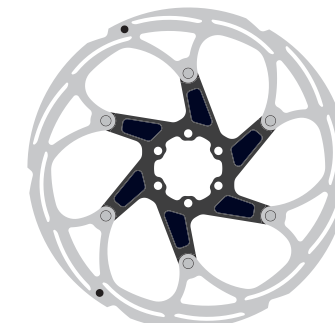

203mm

191g

DR-18

E-scooter rotor

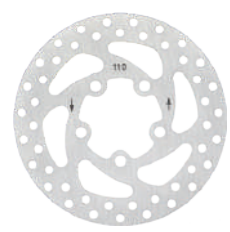

110mm

80g

Xiaomi®
Gotrax®



120mm

102g

Swagtron®

FR-11SA



220mm

271g

2mm extra thickness,
more heat absorbed

FR-16SA



140mm / 160mm / 180mm / 203mm

104g

118g

142g

188g

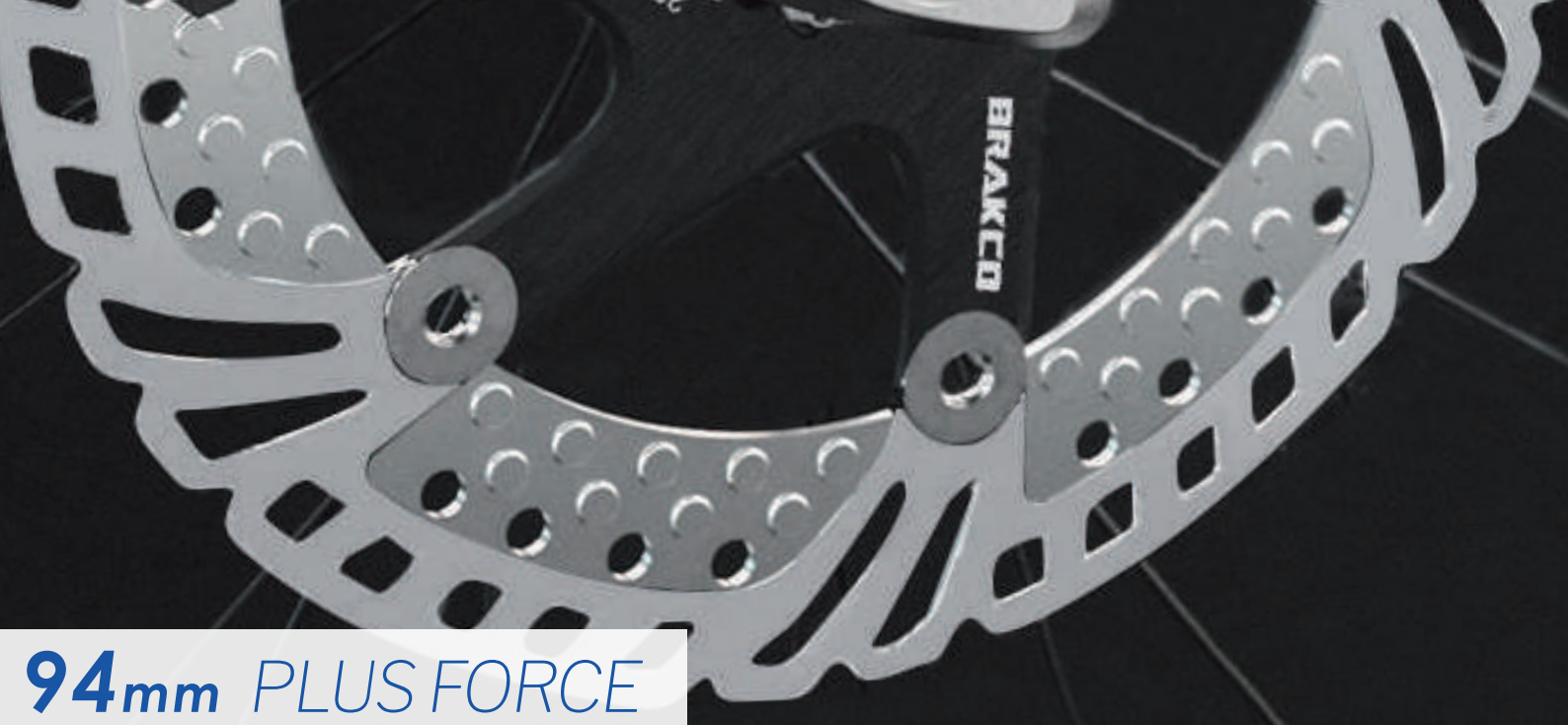

94mm PLUS FORCE

FR-11SA 254mm

The rotor designed to handle the heavier and faster bikes designed to maximize speed and acceleration



BRAKE SHOES

E-BIKE



M-950

- > Length: 50mm
- > Compatible with MAGURA hydraulic brake



M-971V

- > Length: 75mm
- > For E-bikes and heavy loaded bikes



M-972V

- > Length: 80mm
- > For E-bikes and heavy loaded bikes

CARBON

Compatible with SHIMANO® system



R-502

- > Direct reaction both in wet and dry condition.
- > 30% more braking power.

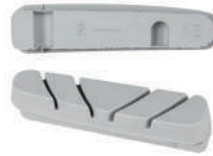

R-716

- > Larger braking surface to minimize heat build-up from pad to rim friction and dissipate heat away to ensure smooth, predictable braking.
- > Four angled slots that move air and water through them, offering increased cooling in dry condition, and increased control in wet condition.
- > More stopping power.
- > Removes dust and water efficiently.



DISC BRAKE PAD



BP-68&SP-68

- > FORMULA CULA 4
- > Sintered compound available



BP-69&SP-69

- > HAYES DOMINION A4
- > Sintered compound available



BP-70T

- > Tranquila compound only
- > Campagnolo DB-310

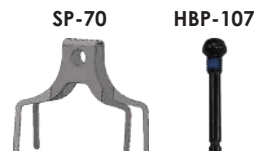

ADAPTOR

CMA

CMA-19 / PM-PM 180 to 203



CMA-27 / PM-PM 160 to 220



CMA-33 / PM-PM 180 to 220



STANDARD

► Postmount caliper to postmount fork for 220mm rotor

AP-27 / PM-PM 160 to 220



AP-33 / PM-PM 180 to 220



AP-35 / PM-PM 203 to 220



► Flat mount system for 180mm rotor

► To solve overheating problem for heavier riders

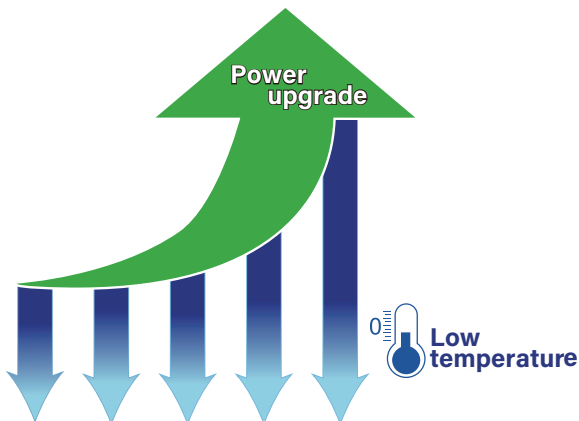

	POST MOUNT CALIPER	FLATMOUNT CALIPER
	180mm rotor	
FLATMOUNT FORK	<p>AP-25</p>	<p>AP-24</p>
FLATMOUNT FRAME	<p>AP-21</p>	<p>AP-22</p>

ADAPTER CONVERSION KITS FOR BOOST HUB

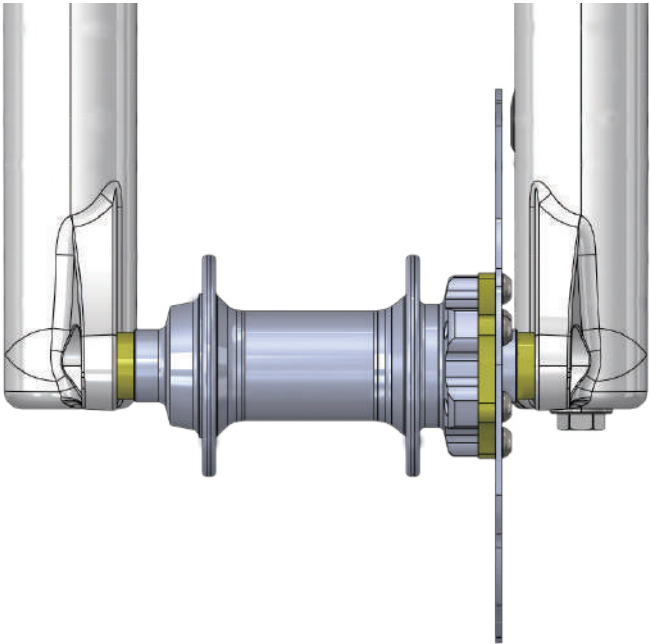
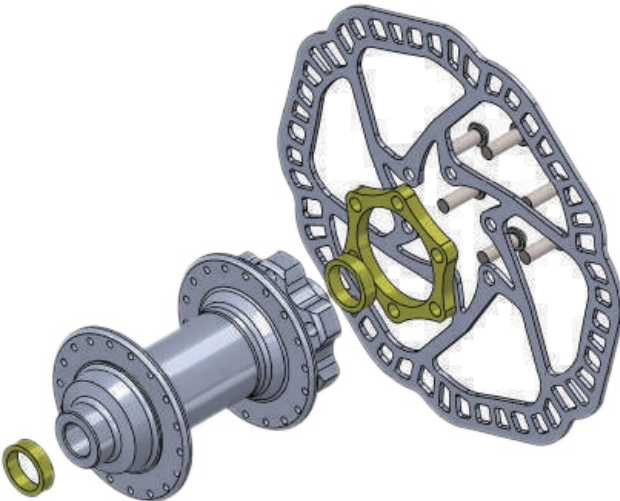

CL-06

Fits boost fork at specification of 15 x110mm
5mm thickness



CL-07

Fits boost frame at specification of 15 x110mm
3mm thickness



CL-WS-05

- >0.2mm thickness
- >Aligning the rotor

BLEEDING KITS

This kit allows a fast and easy bleeding. The bleeding kits offer an optimized routing for the brake fluid which allows filling and bleeding through the same hole.

HK-08



INCLUDING :

- HBP-106 Funnel and stopper
- HBP-45 Syringe
- HBP-47 PU hose
- HBP-48 Clip

HK-09

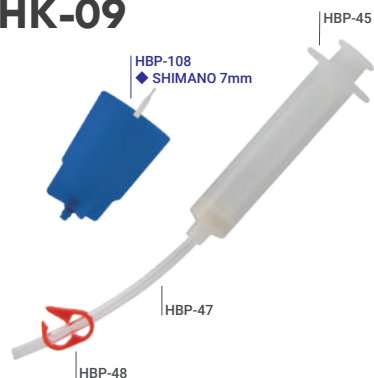

INCLUDING :

- HBP-108 Funnel and stopper
- HBP-45 Syringe
- HBP-47 PU hose
- HBP-48 Clip

HK-10



INCLUDING :

- HBP-109 Funnel and stopper
- HBP-45 Syringe
- HBP-47 PU hose
- HBP-48 Clip

SHIMANO

BT-079



BT-080



BT-081



MAGURA

BT-083

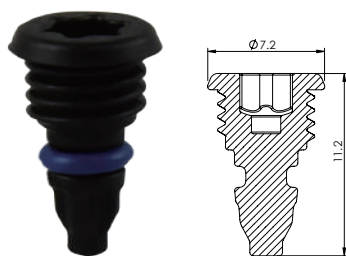

SRAM

BT-084



TEKTRO

BT-085



HAYES

BT-086

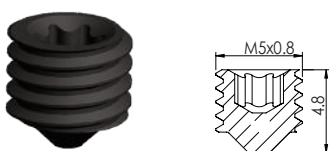

SRAM

HBP-102

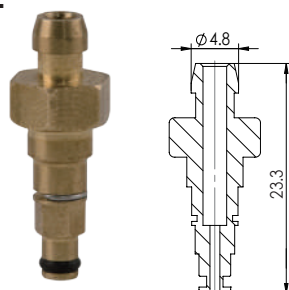

FLATMOUNT BOLT COLLECTION ASSORTMENT KIT

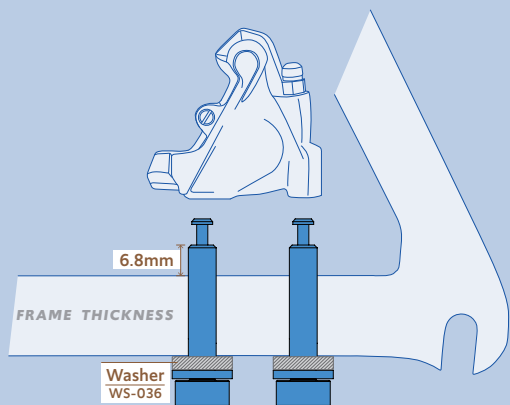

>In case of using 140mm disc rotor for rear disc brake
>for length adjustment when needed

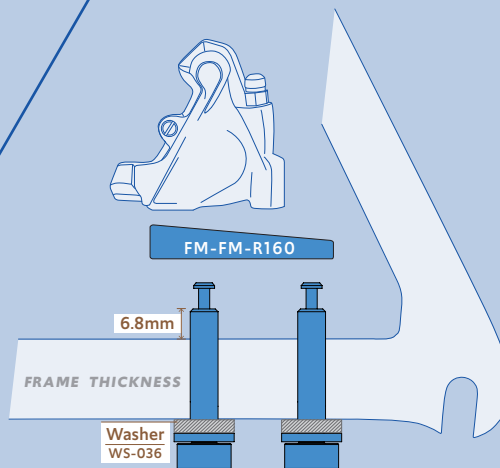

>In case of using 160mm disc rotor for rear disc brake
>for length adjustment when needed

CONVERTER FIXING BOLTS

BT-088

> M5 x 23mm



BT-089

> M5 x 28mm



BT-090

> M5 x 33mm



BT-091

> M5 x 38mm



BT-092

> M5 x 43mm



BT-093

> M5 x 48mm



FIXING BOLTS

BT-045

FM-FM adaptor to caliper
> M5 x 18mm



BT-047

FM-PM adaptor to fork
> M5 x 14mm
> Use on PM-FM-F140 /
PM-FM-F160



BT-051

FM-FM adaptor to fork
> M5 x 14.5mm
> Use on FM-FM-F140/160



FIXING NUT

HBP-59+WS-016

FM-PM adaptor to caliper
> M6 x 14.3 nut with washer
fits adaptor bolt of
PM-FM-R140 /
SHIMANO SM-MA-R140 P/D



WASHER

WS-036

> O.D. : 10.8mm
> THICKNESS : 2.6mm



CLIP

HBP-99

> Clips fits M4/M5 fixing bolts



PARTS

Disc Brake Multiple Tool HBP-98

Material: SUS 410



1. Locking Wrench: to lock and unlock CL disc rotor locking.
2. 5mm Hexagon key extension: to extend 5mm Hexagon key leverage.
3. Hydraulic Brake Piston Press: to spread the pads and compress the pistons.
4. Rotor Truing fork: to true the bent rotors.
5. Rotor and Disc Brake Pad thickness measuring gauge: to measure and check the rotor and disc brake pads M.I.N thickness.

Disc Brake Caliper Alignment Tool MBP-71

Material: 7075 Alloy Full CNC machined and Stainless steel



1. Rotor aligning:
set the correct clearance between the brake pads and rotor. The two thin plates simulate the clearance between the brake pads and rotor.
2. Piston pressing: re-set the piston into the caliper.

Rotor and Disc pads Wear Indicator TL-001

Material: Full CNC machined

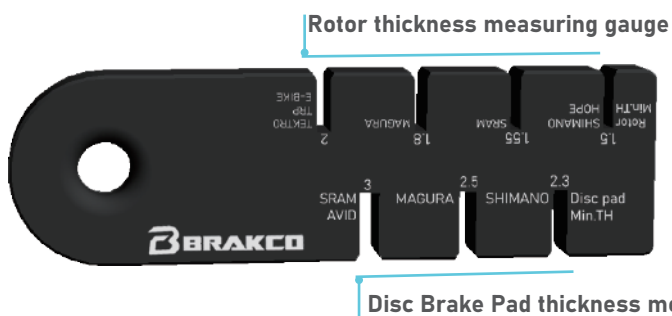

Rotor and Disc Brake Pad thickness measuring gauge: to measure and check the rotor and disc brake pads M.I.N thickness.

MBP-20
2 PISTON SPACER



MBP-77
4 PISTON SPACER



MBP-64
M5 hex key for adapter AP-24



MBP-72
Fits 2.5mm Di2 E-wire & 5mm housing



MBP-73
Fits 4mm & 4mm housing



MBP-74
Fits 4mm & 5mm housing



MBP-75
Fits 5mm & 5mm housing



HBP-92
SHIMANO
STEEL
M9x1.25
Flange bolt fits SHIMANO
ST-R9170/R9120/R8070/R8020



HBP-93
MAGURA
STAINLESS
M5x0.8
Banjo bolt fits for MAGURA
MT4/5/6/7/8 after 2015 year



HBP-94
TEKTRO
STAINLESS
M6x1.0
Bleeding adapter with o-ring fits
TEKTRO M6



HBP-101
SHIMANO
STEEL
M8x0.75
NUTS



BLEEDING BLOCK HBP-103

for off-center fixing hole



BLEEDING BLOCK HBP-104

for 4 piston brakes



BLEEDING BLOCK HBP-105

for 2 piston brakes



HBP-110
HOPE
NEEDLE



HBP-111
HOPE
7x5.1x5.9mm
Oliver



HBP-112
HOPE
9.9x6.3x1mm
COPPER O-RING



HBP-113
HOPE
6.6x3.3x0.8mm
COPPER O-RING





ROTOR
STANDARD
SPORT
PRO



BRAKE SHOE
MTB
ROAD
CARTRIDGE



ADAPTOR
CMA
STANDARD



BRAKE PAD
DISC PAD
BPX
BPF



BRAKCO INDUSTRY CO., LTD.

No.577, SEC. 1, FANHUA RD., FUSING TOWNSHIP,
CHANGHUA COUNTY 506, TAIWAN

TEL : 886-4-7794916 FAX : 886-4-7794917

E-MAIL : brakco@brakco.com.tw